

Bentley “Collaborations”



Graeme Louw P.E. & Alan Fritz
June, 2026

POWER LINE[®]
S Y S T E M S
Part of Bentley Systems

Bentley®

Solutions for Project Delivery and Asset Performance

Bentley's **mission** is to reshape how infrastructure systems and critical resources are delivered and optimized.



Road



Bridge



Rail Network



Water Network



Renewables



5G



Utilities



Digital Factories













































Water Treatment



Digital Cities

Bentley's Product Library

 ADINA	 AssetWise	 AutoPIPE	 BCDE
 BECS	 Bentley Infrastructure Cloud	 Bentley LumenRT	 Bentley OpenPaths
 Blynscy	 Cesium	 Civil Worksuite	 EasyPower
 iTwin Capture	 iTwin Engage	 iTwin Experience	 iTwin IoT
 MicroStation	 MOSES & Maxsurf	 OpenBridge	 OpenBuildings
 OpenCities Map	 OpenFlows	 OpenFlows WaterSight	 OpenPlant
 OpenRail	 OpenRoads	 OpenSite+	 OpenTower
 OpenTunnel Designer	 OpenUtilities Designer	 OpenUtilities Map	 OpenUtilities Substation
 OpenUtilities Substation+	 Power Line Systems (PLS)	 ProjectWise	 ProStructures
 RAM	 SACS	 Sequent Products	 SPIDA
 STAAD	 SYNCHRO	 Talon	

Bentley Collaborations

 **Infrastructure Cloud**

 **SYNCHRO™ 4D Pro**

 **STAAD® Foundation Advanced**

 **ADINA®**



All integration to Bentley Infrastructure Cloud (BIC) is via done PLS-GRID.

- This is done when checking a Project in to PLS-GRID you can export an iTwin.

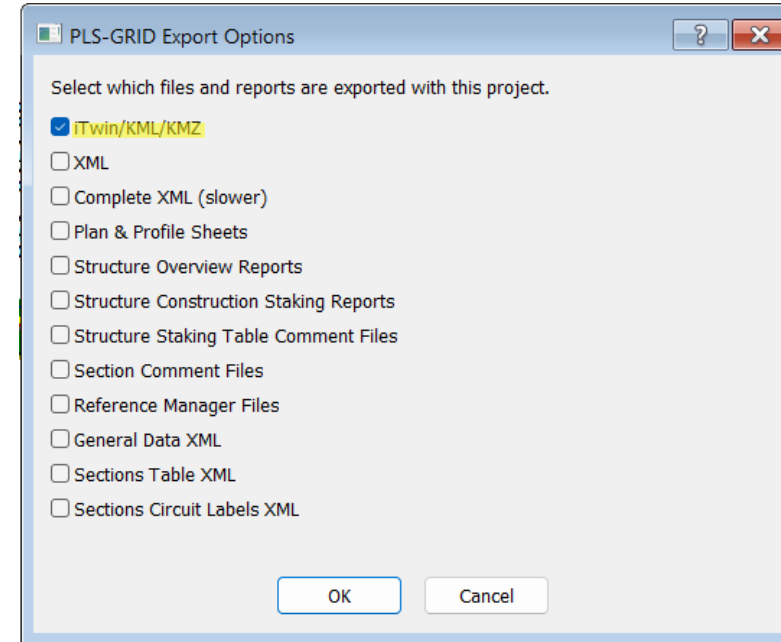



All integration to Bentley Infrastructure Cloud (BIC) is via done PLS-GRID.

- This is done when checking a Project in to PLS-GRID you can export an iTwin.
- This allows you to interfaces with other Bentley products from this "Digital Twin".
 - ProjectWise + SYNCHRO + AssetWise

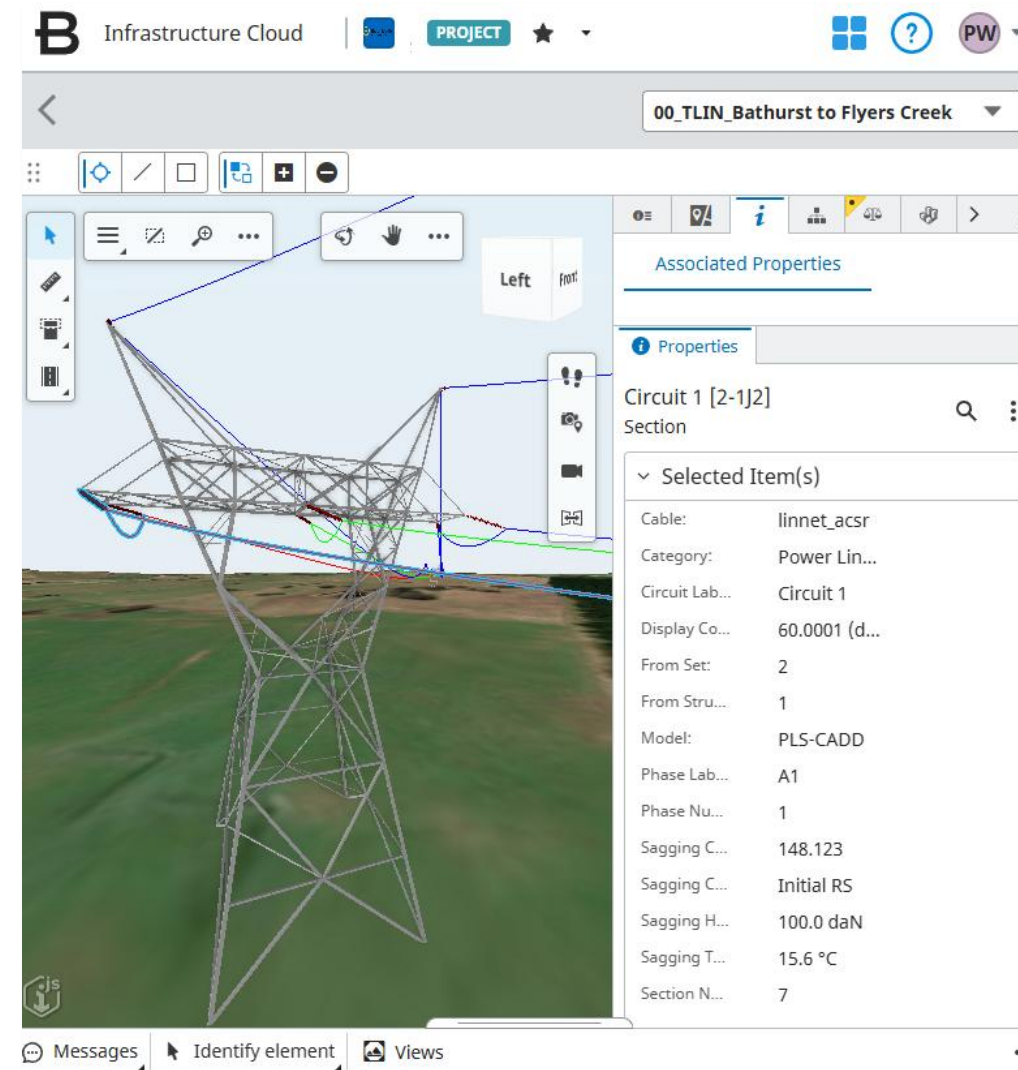

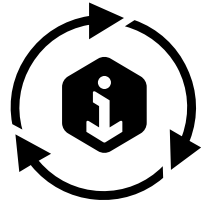
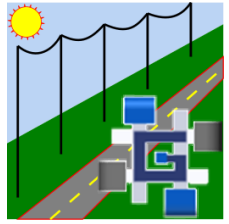

Infrastructure Cloud

All integration to Bentley Infrastructure Cloud (BIC) is via done PLS-GRID.

- This is done when checking a Project in to PLS-GRID you can export an iTwin.
- This allows you to interfaces with other Bentley products from this "Digital Twin".
 - ProjectWise + SYNCHRO + AssetWise
- One example of what you can do is to export the model in an ***.IFC** file format.

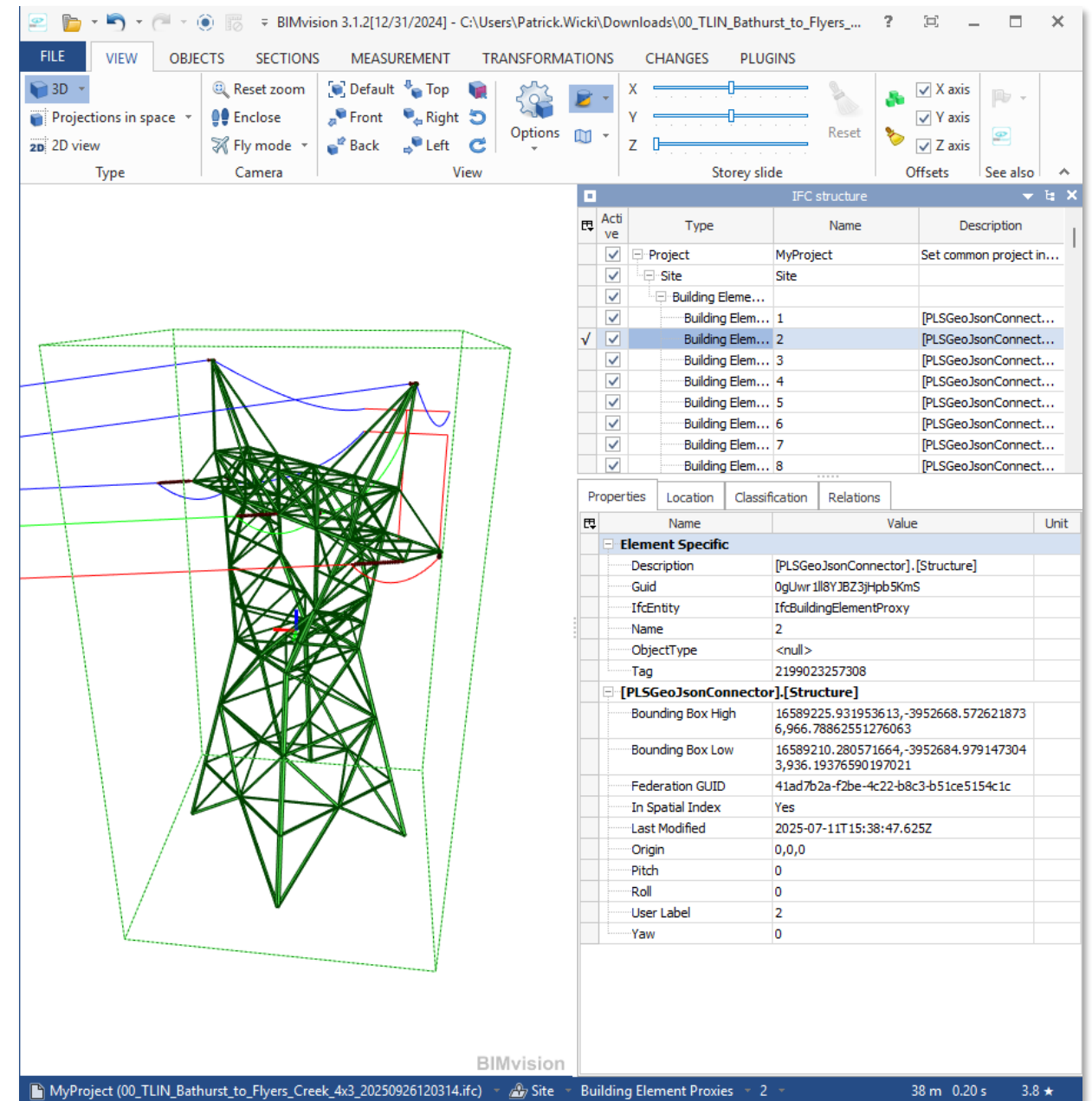

Bentley Collaborations

 **Infrastructure Cloud**

 **SYNCHRO™ 4D Pro**

 **STAAD® Foundation Advanced**

 **ADINA®**



SYNCHRO™ 4D Pro

Digital construction delivery software

SYNCHRO's digital construction delivery software integrates **high-value construction data**, such as schedules, quantities, and progress data with comprehensive engineering information, **empowering teams** to achieve better project visibility, program validation, and risk reduction throughout the project lifecycle.

SYNCHRO leverages existing information, enriching it with construction planning data, rather than recreating information and reducing productivity.



Visual planning

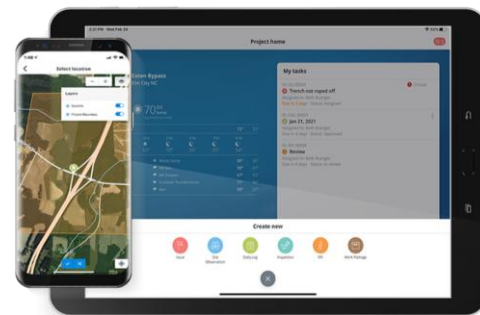

Field execution



Productivity tracking

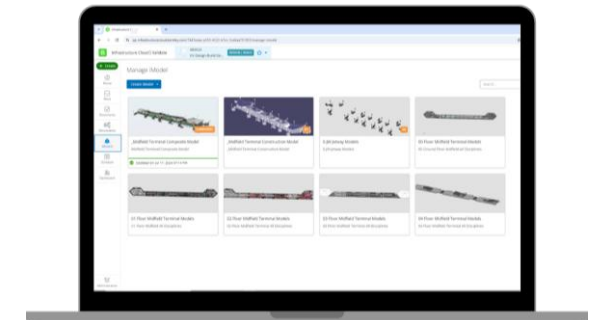

Project management

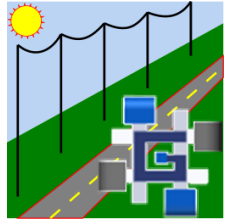

To use PLS-CADD models for SYNCHRO project management is possible right now
 -> PLS-GRID -> BIC -> SYNCHRO.

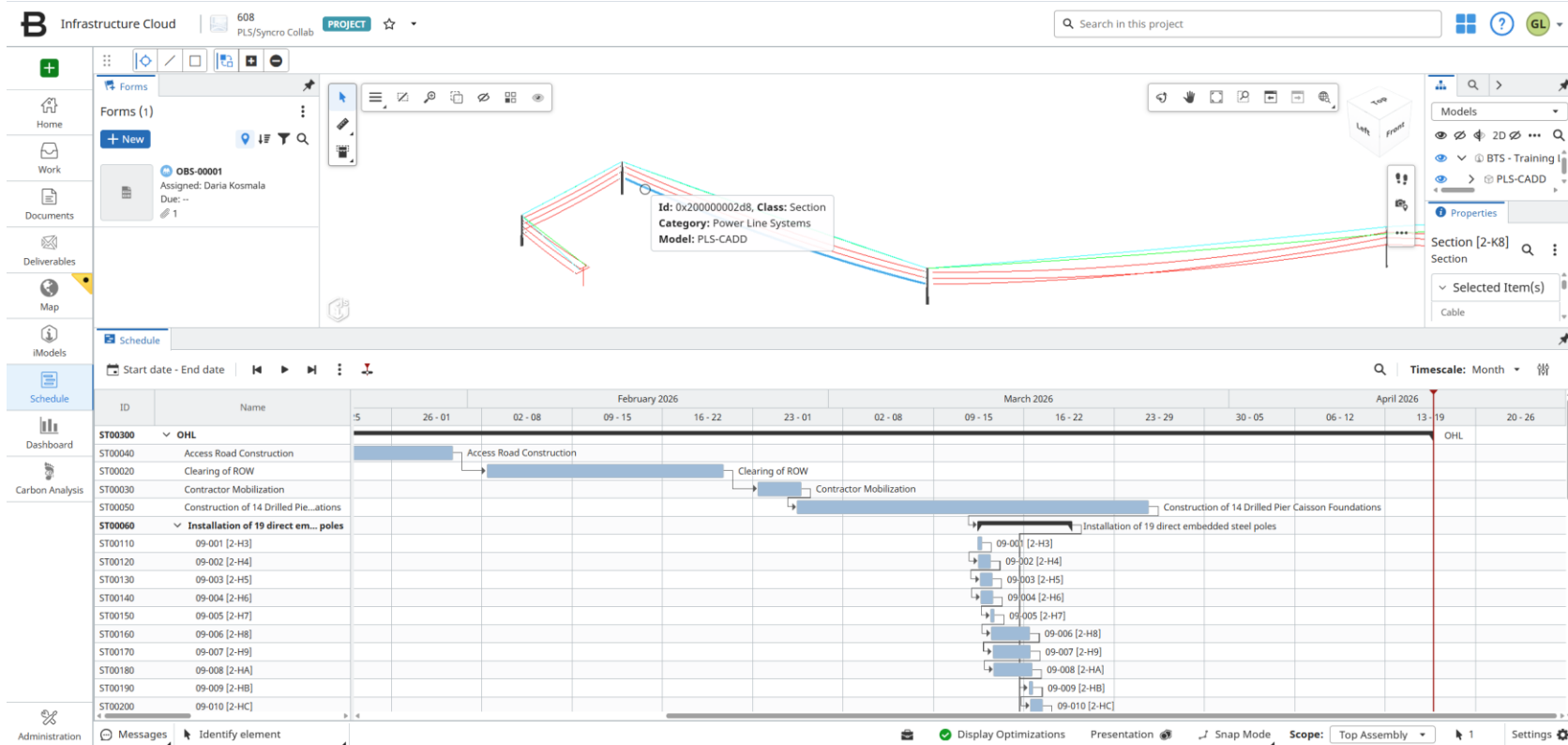

46	S.	Stringing Con...	7d	4/1/26	Stringing Conductor and Shield Wire
47	S.	09-003	1d	4/1/26	09-003
48	S.	09-017	4d	4/2/26	09-017
49	S.	09-018	1d	4/8/26	09-018
50	S.	09-019	1d	4/9/26	09-019
51	S.	SUB	1d	4/9/26	SUB
52	S.	Final Sagging...	2d	4/10/26	Final Sagging - clipping in wire
53	S.	Final Inspection	1d	4/14/26	Final Inspection
54	S.	Substation C...	2d	4/15/26	Substation Connections

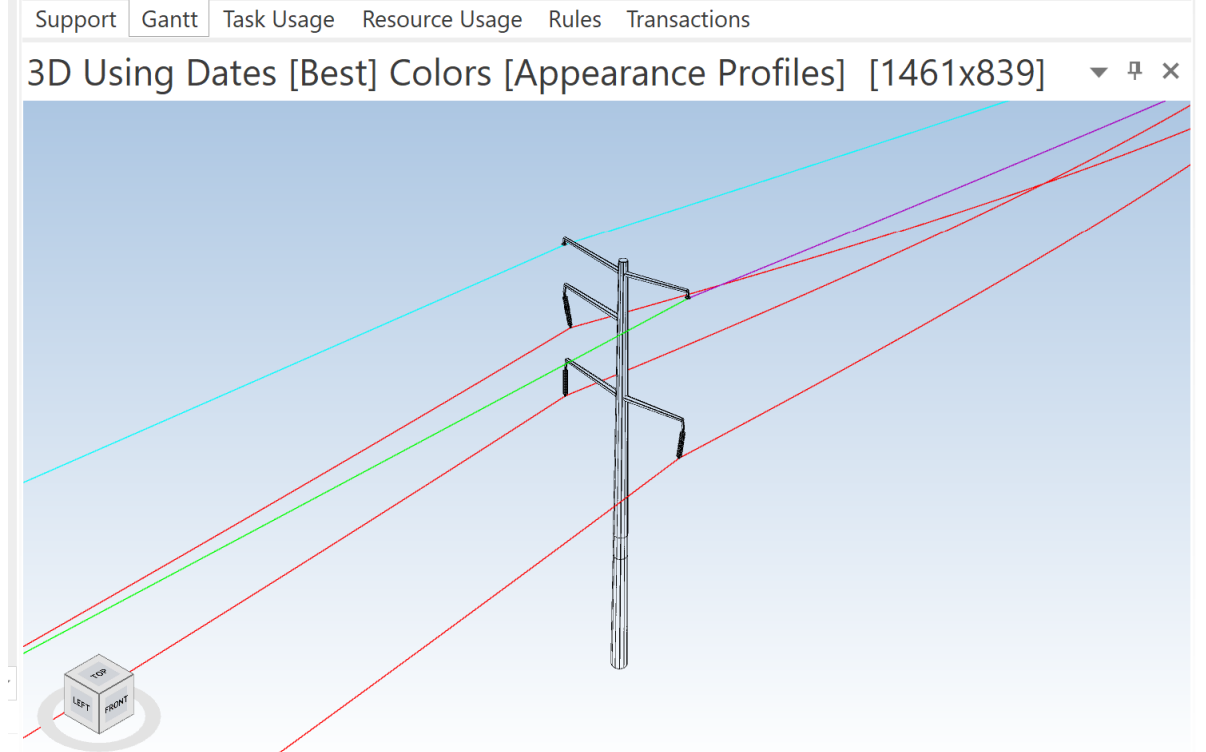

Bentley Collaborations

 **Infrastructure Cloud**

 **SYNCHRO™ 4D Pro**

 **STAAD® Foundation Advanced**

 **ADINA®**



STAAD® Foundation Advanced

Bentley's foundation design software SFA '26 includes:

- Mat foundations
 - With/ without piles
- Isolated footings
- Combined footings
- Pile caps
- Pedestals
- Import multiple models for foundation design
- Parallel processing of foundations
- Drawing generation
- Automation using python scripts
- Bentley Copilot for AI driven modelling (TP)

Design Codes:

- ACI 318-14, 19
- IS 456
- EC2 & EC7

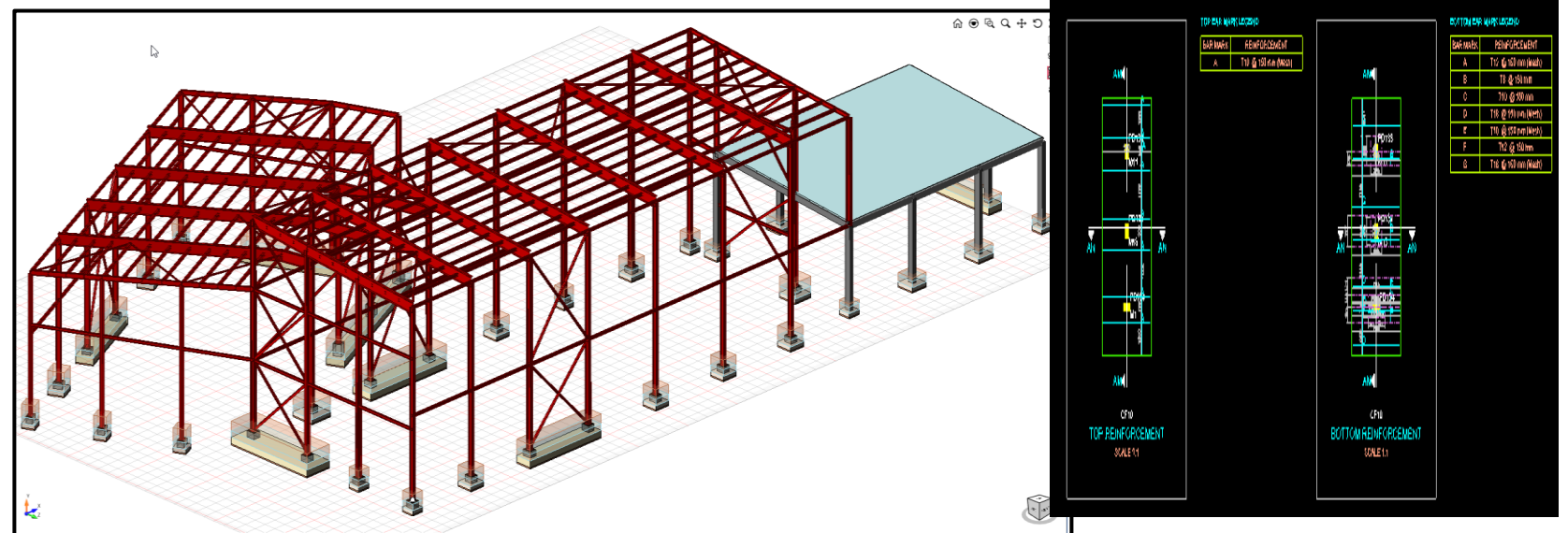
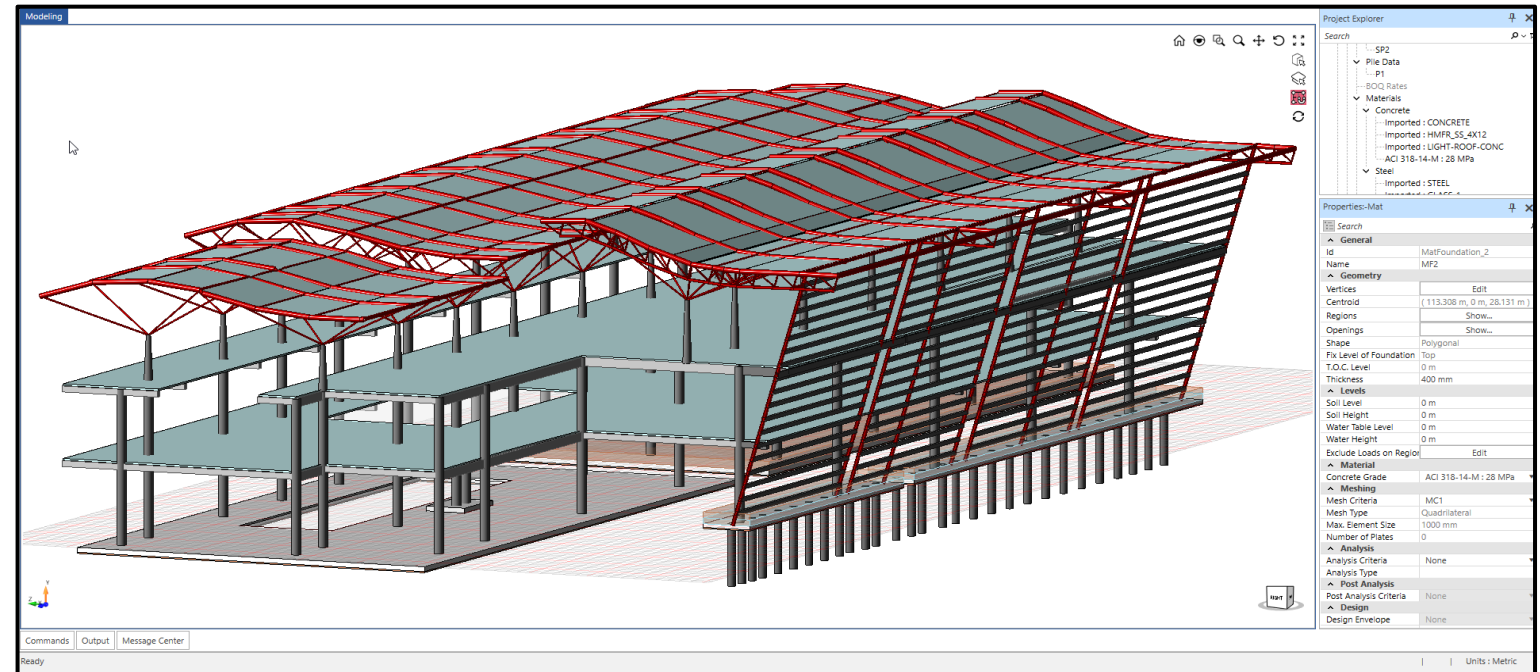

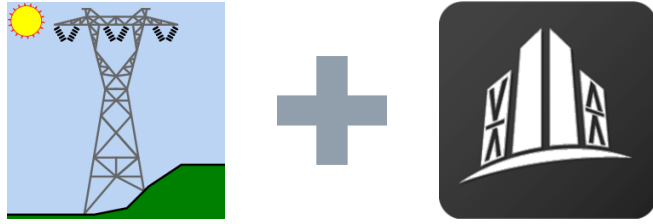

Planned Integration:

- Output Option to create a ***.JSON** file as an input to SFA.
- Will include:
 - Foundation Joint location
 - Reactions (for load cases/combinations)
 - Member orientation + cross-sectional properties
- ****Aims**** to streamline the start of the SFA design process.
- *Long-term goal to include PLS-POLE, Guy anchors and integrate with a full PLS-CADD model.*

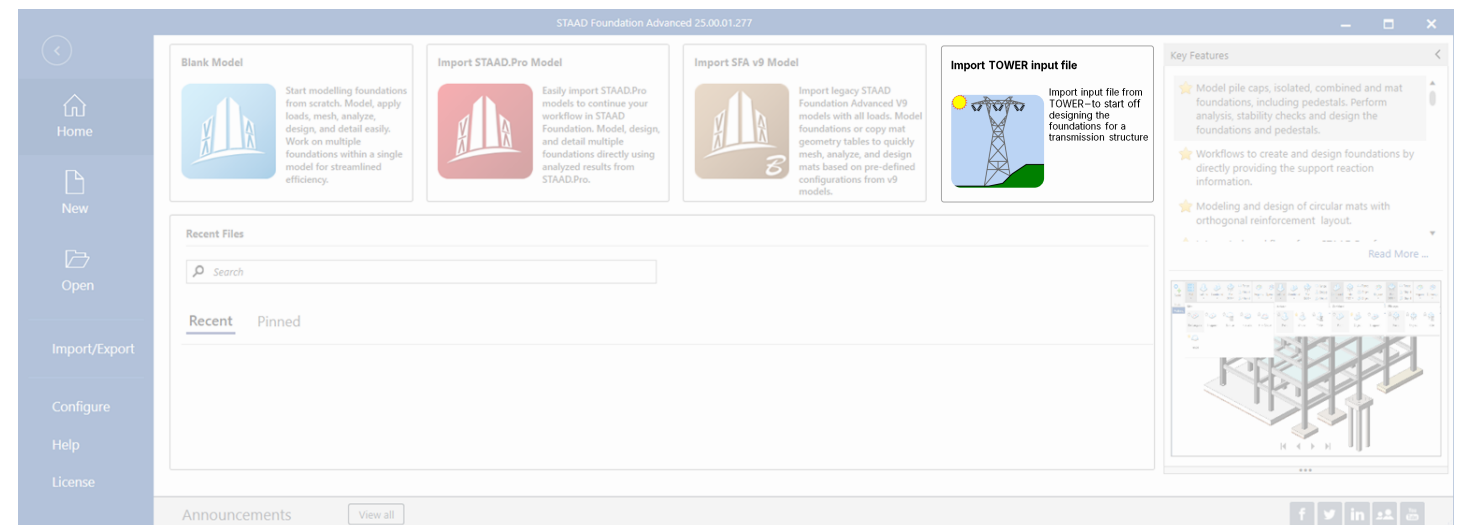
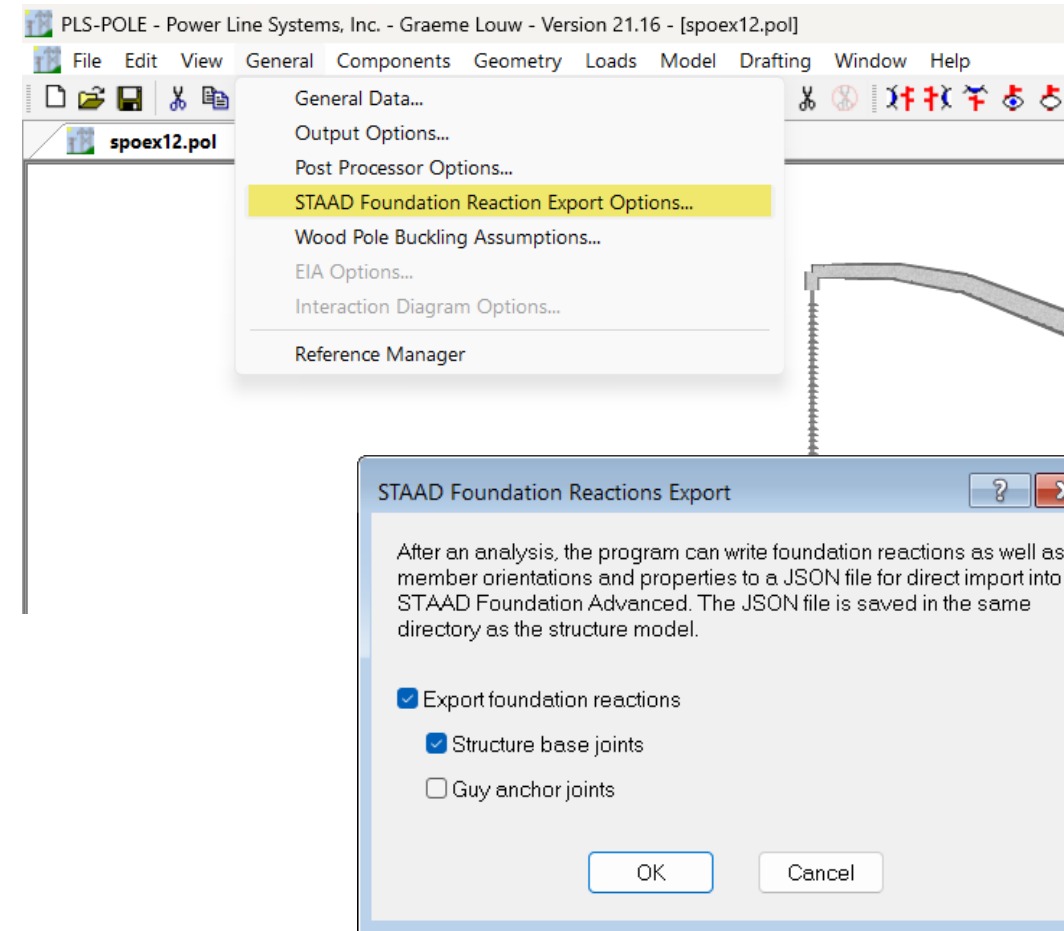

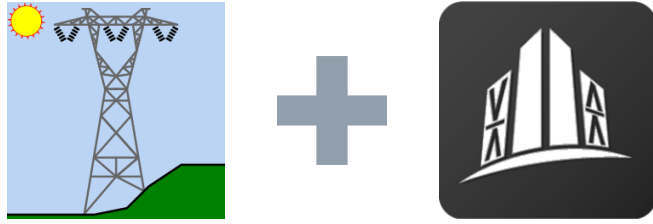

What can you currently do in SFA?

- Import a TOWER model as a ***.DXF** wireframe
 - Model the primary steel members for more precise setting out, if necessary.
 - Position the foundations and/or pedestals
- Import Reactions from PLS Tower (*manual import/matching for now*)
 - Reactions can be specified w.r.t:
 - Global axis system
 - Local axis system of the pedestal / foundation

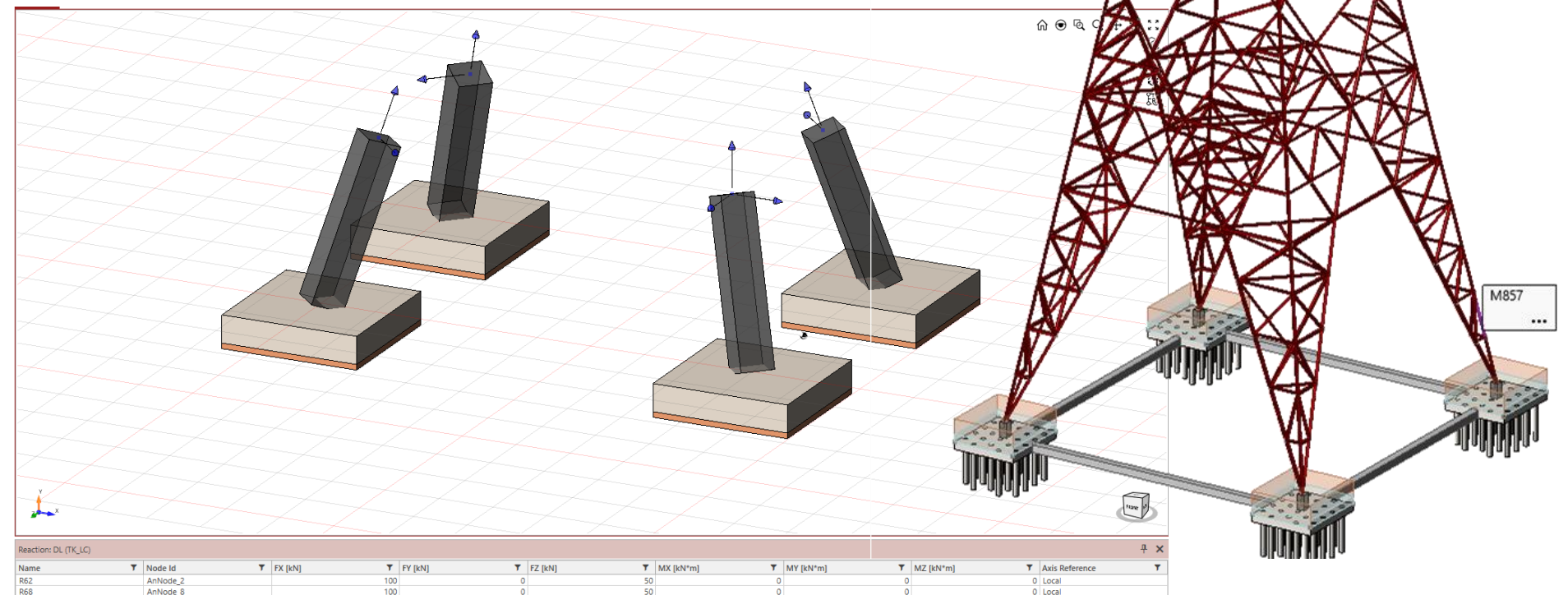

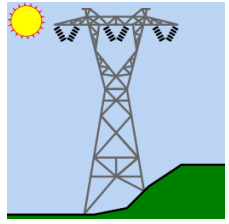

- Create and modify foundation types

- Currently supports Pads, Combined Footings, Pile caps, Mats (Rafts) with/ without additional pile supports
- *Tie beams feature shown is currently indicative*

- Modify foundations:

- Adjust geometry
- Adjust foundation levels,
- Adjust soil layers and/or water levels as necessary

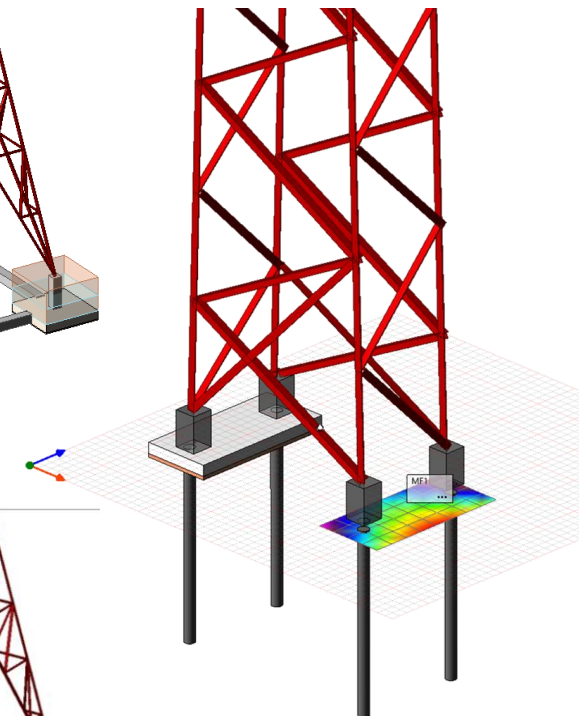
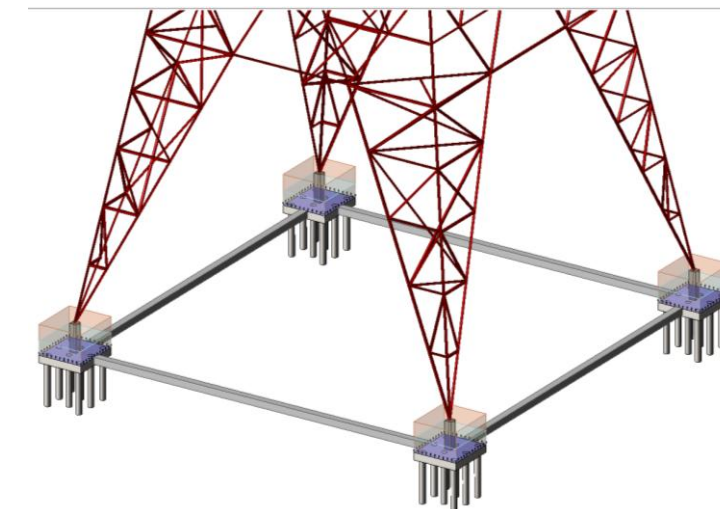
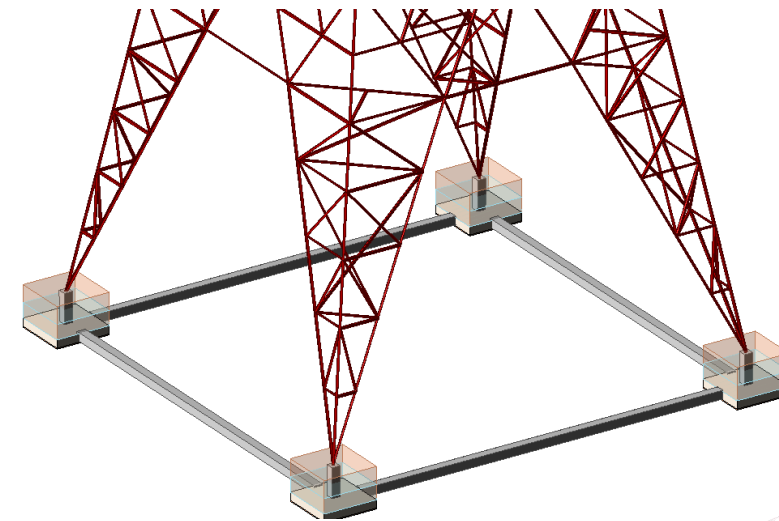
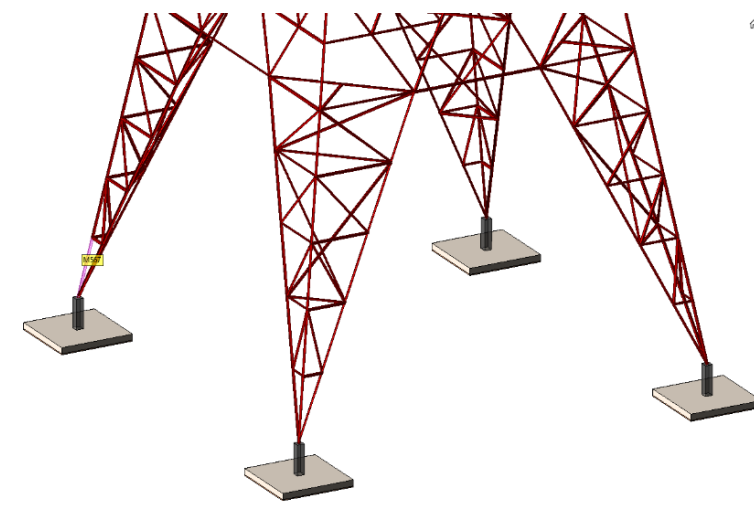
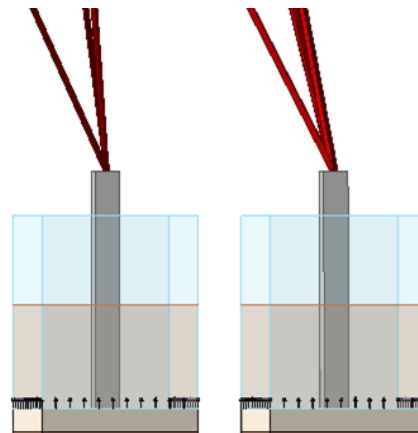
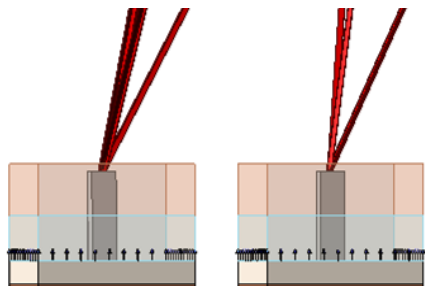

Bentley Collaborations

 **Infrastructure Cloud**

 **SYNCHRO™ 4D Pro**

 **STAAD® Foundation Advanced**

 **ADINA®**



ADINA®

Advanced Finite Element Analysis – Infinite Possibilities

ADINA Structures offers:

- Geometric, material and load nonlinearities
- Large Deformations
- Frictional contact between structural components
- Low speed dynamics for collapse analysis of structures
- Impact analysis
- Frequency analysis and modal superposition technique
- Buckling and post-buckling analysis

ADINA also offers:

- Thermal and Thermo-mechanical coupling
- Computational Fluid Dynamics
- Fluid Structure Interaction
- Electromagnetics
- Multiphysics

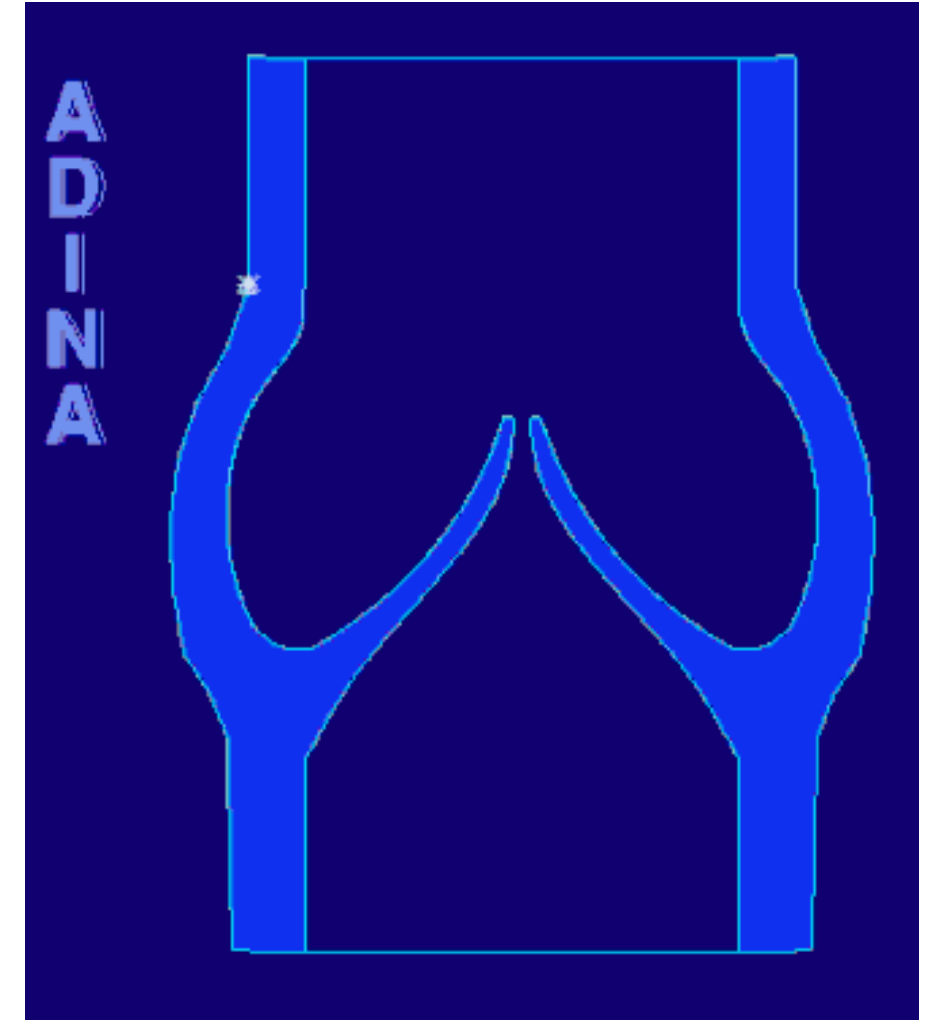

Fluid-structure interaction (FSI) results of an aortic heart valve, obtained by coupling the ADINA modules. The simulation was used to study how sinuses behind the aortic valve leaflets produce vortices that aid in closure with minimal transvalvular pressure.

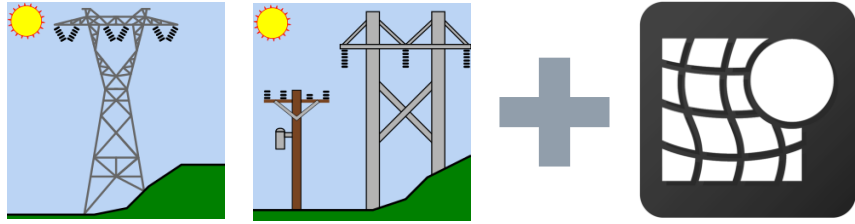

This provides:

- Initial setup of ADINA models via PLS-POLE and Tower models
- Export of low-level SAPS FEA data to ADINA
- The potential to apply the full capabilities of ADINA to PLS models

Current Status:

- In the very earliest stages of development
- Only minimally validated using (confidential) client Tower models
- Not yet exposed in the UI of PLS-POLE or Tower
- For PLS internal development and evaluation only

The next slide shows an example of the dynamic analysis of:

- A single PLS-POLE tangent steel pole
- Ahead and back conductor spans
- Seismic ground movement
- Broken conductors

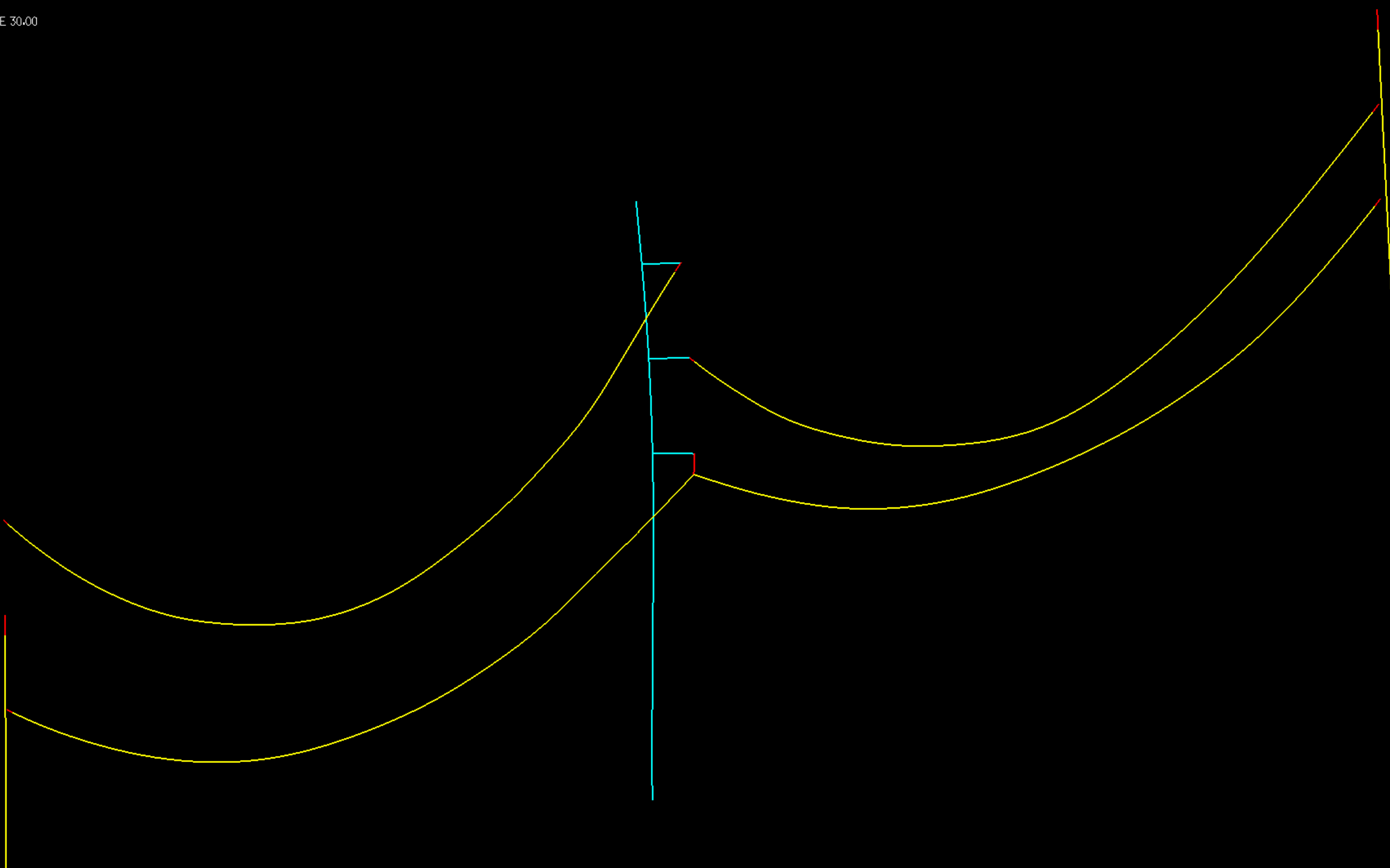

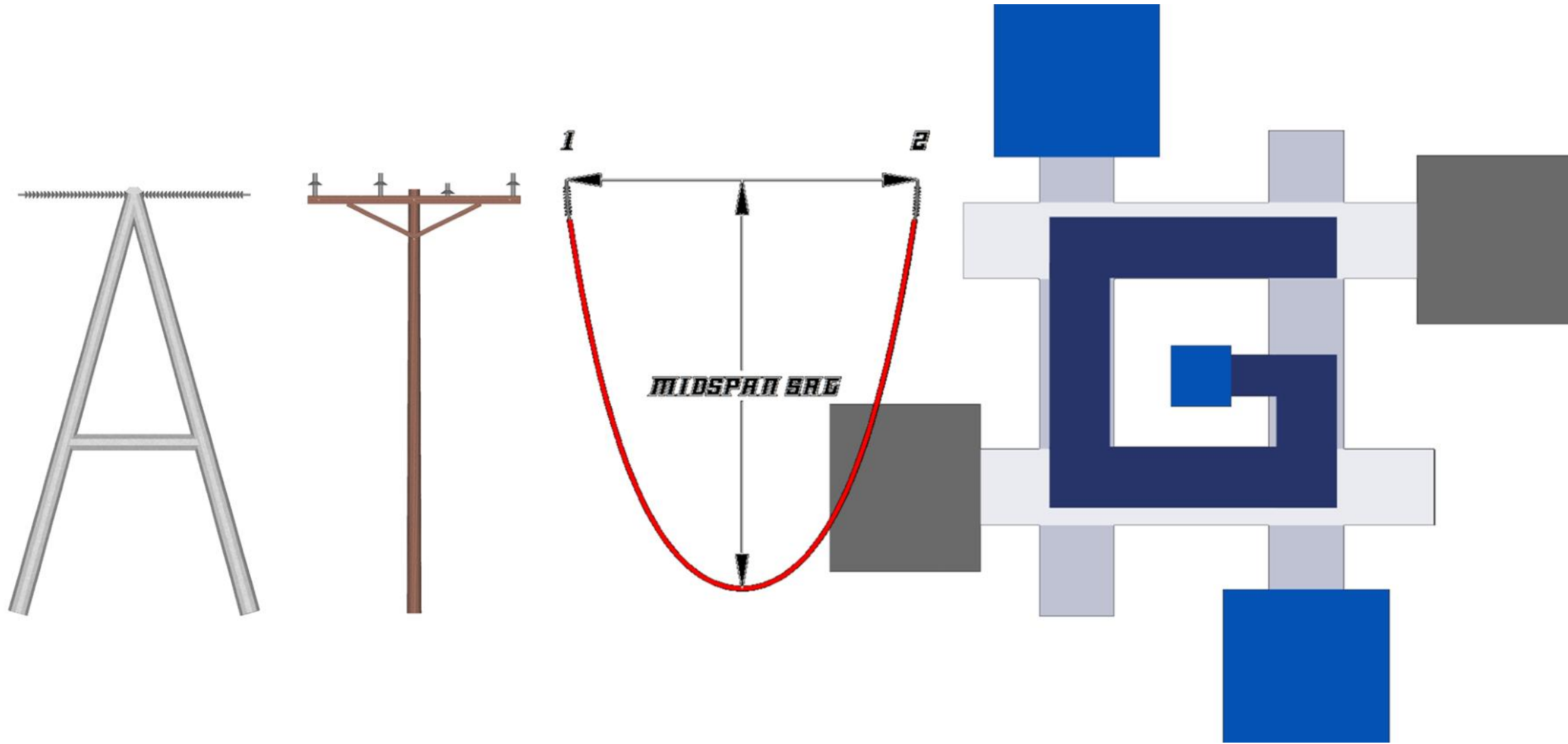

support@powerlinesystems.com